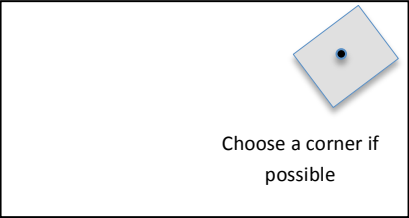
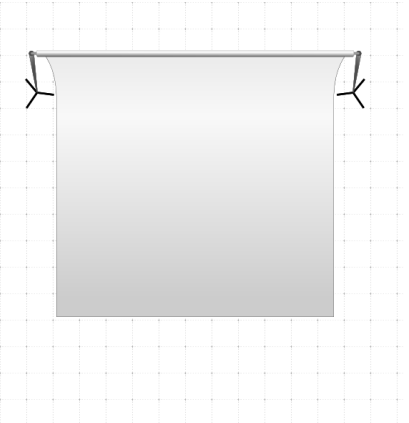
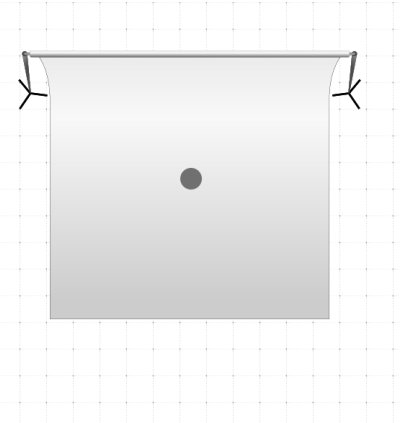

Setting Up for Shooting Consistent, Well-Lit Portraits

Purpose To set up a backdrop and three-point lighting system for shooting consistent, well-lit portraits.

When Upon arrival in the room reserved for the photographer to shoot portraits.

- Materials** A portable studio kit with
1. Backdrop, support bar, and support stands
 2. 3 photo floods with tripods, 2 white umbrellas, and snoot
 3. Camera, tripod, and accessories (batteries, hard cards, remote, etc.)
 4. Stool and cardboard box about 4 feet high.

| Actions | Steps |
|--|--|
| <p>1. Select the location.</p>  | <ol style="list-style-type: none"> a. Choose a location in agreement with the school or company, ideally in a corner without any nearby doors, to minimize traffic behind the studio. b. Look for at least a 10' ceiling to minimize ceiling reflection and allow for the raised 8' backdrop |
| <p>2. Set up the backdrop.</p>  | <ol style="list-style-type: none"> a. Lay out the continuous 10' x 20' drop cloth-backdrop. b. Thread the support pole through the 10' end and raise it 8' high, between the two extended support tripods. |
| <p>3. Place the stool and target.</p>  | <ol style="list-style-type: none"> a. Position a stool in the center of the drop cloth. b. If a person of average height (for those you will be photographing, e.g. 5th graders) is available, pose them on the stool facing forward. c. Otherwise place a packing box about 4 feet high on the stool as a target for camera placement. |

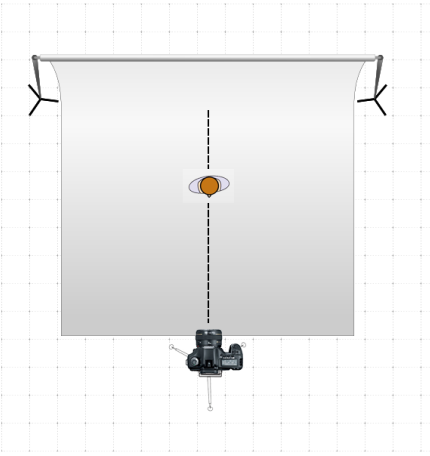
4. Set up the camera.

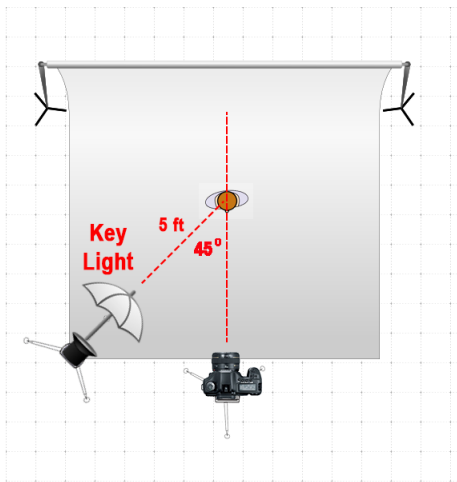

- Set up the camera on a tripod at anticipated eye level for a sitting subject.
- It should allow the subject to be framed (using the usual lens) according to portrait guidelines.
- Plan to adjust the camera height at the **eye level** of each subject.

5. Set up the Key Light.

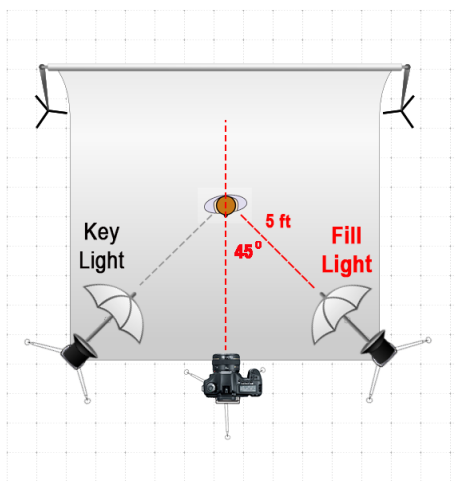
- Set up the **Key light** with attached umbrella on a tripod.
- Set the key **5 feet** from the subject to **camera left**, at a 45 degree angle between subject and camera.
- Turn on the key light at **full power**.
- Raise the tripod such that the light is focused on the subject, about **2 feet** higher than eye level.
- The Key light should be outside the frame when viewed through the camera.

6. Set up the Fill Light.

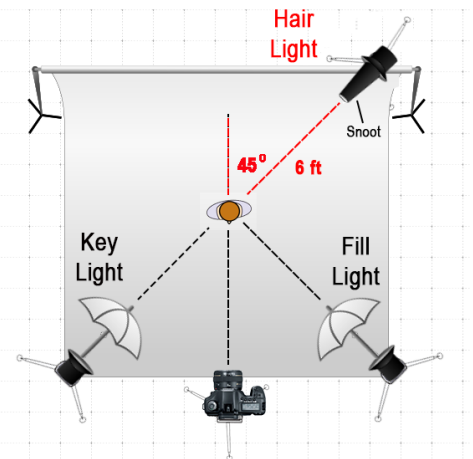
- Set up the **Fill light** with attached umbrella on a tripod.
- Position it **5 feet** from the subject to camera right, at a **45 degree** angle between subject and camera.
- Turn on the fill light to **half power**.
- Raise the tripod such that the light is focused on the subject, about **1 foot** higher than eye level.
- The Fill Light should be outside the frame when viewed through the camera.

| | |
|--|--|
| <p>7. Set up the Hair Light.</p>  | <ol style="list-style-type: none"> Set up the Hair light with a snoot. The tripod will need to extend at least 8.5 feet to clear the backdrop. Position it 6 feet behind the subject at camera right, opposite the main light (along an invisible line running between them through the subject). This should be 45 degrees to an invisible line running from camera to subject. Turn on the light to half power. Focus the light where the left back of the subject's head will be. |
| <p>8. Shoot test exposures</p>  | <ol style="list-style-type: none"> Shoot a test exposure to determine the quality of the lighting set up and the right exposure. Dismiss your test subject with thanks, or remove and stow the box on the stool. Turn the floods out until 15 minutes before the first anticipated portrait, and allow them to warm up. |
| <p>Result A studio with consistent and standardized 3-point lighting is ready for shooting portraits.</p> <p>Standards</p> <ul style="list-style-type: none"> Cases and storage equipment are neatly stacked in another room or behind the backdrop, out of sight. Lights are positioned at the correct angle to, and distance from, the subject. Lights are set to the correct power setting. Subjects should be well-lit by the Key, shadows removed by the Fill, and subject is set off from the background by the Hair light. Setup backdrop, camera, and lights in less than 15 minutes. | |